

ROBINSON WILLEY

The hottest name in heating

RIVIERA G C No. 32-170-23

AND

BELVEDERE G C No. 32-170-24

Cat II_{2H3P} G20 at 20mbar convertible to G31 at 37mbar.
For use in GB and IE.



Installation & Servicing Instructions

The Data Badge and Serial Number are located on the left hand side of the base panel.

PLEASE LEAVE THESE INSTRUCTIONS WITH THE USER

This product uses fuel effect pieces containing Refractory Ceramic Fibre (RCF), which are man-made vitreous silicate fibres. Excessive exposure to these materials may cause temporary irritation to eyes, skin and respiratory tract, consequently, it makes sense to take care when handling these articles to ensure that the release of dust is kept to a minimum.

To ensure that the release of fibres from these RCF articles is kept to a minimum, during installation and servicing we recommend cleaning should be carried out in a well-ventilated area or in the open air, by gently brushing with the pieces held away from your face so that you avoid inhaling the dust. We do not recommend the use of a normal domestic vacuum cleaner, which may blow dust back into the air. *If a vacuum cleaner is recommended for use by your organisation, you must use a HEPA filtered vacuum to remove any dust and soot accumulated in and around the fire before and after working on the fire.* When replacing these articles we recommend that the replaced items are not broken up, but are sealed within heavy duty polythene bags, clearly labelled as RCF waste. This is not classified as "hazardous waste" and may be disposed of at a tipping site licensed for the disposal of industrial waste. Protective clothing is not required when handling the articles, but we recommend you follow the normal hygiene rules of not smoking, eating or drinking in the work area and always wash your hands before eating or drinking.

Advise the customer that they should read their Users instructions before operating the fire and always follow the advice in the Section headed "Cleaning your Fire".

CONTENTS

	SECTION	PAGE
INTRODUCTION AND GENERAL INSTALLATION REQUIREMENTS		4
TECHNICAL DATA	1.0	4
AVAILABLE FENDERS	2.0	5
AVAILABLE TRIMS	2.1	6
CONTENTS OF SCREW PACK	3.0	7
CONTENTS OF COAL PACK	4.0	7
CONDITIONS OF INSTALLATION	5.0	8
SITING GENERAL	5.1	8
FLUES AND CHIMNEYS	5.2	8
Brick Chimney, 178mm diameter (7 inch)		
Stone or Lined Flue and 125mm diameter (5 inch) Flue	5.2.1	8
Pre-Cast Flue	5.2.2	9
Rebated Surround Installation	5.2.3	9
Metal Fluebox 125mm diameter (5 inch) Flues	5.2.4	11
SHELF HEIGHT AND SIDE CLEARANCES	5.3	12
Combustible Shelf	5.3.1	12
Non-Combustible Shelf	5.3.2	12
INSTALLATION OF FIRE	6.0	12
UNPACKING	6.1	12
PREPARATION OF FIRE	6.2	12
Spigot Restrictor	6.2.1	12
Fender Mask	6.2.2	13
Burner Tray	6.2.3	13
METHODS OF INSTALLATION	6.3	14
Fixing by Tension Cable	6.3.1	14
Fixing Directly to Surround Face	6.3.2	14
GAS CONNECTION	6.4	15
Concealed Connection	6.4.1	15
TEST FOR GAS SOUNDNESS	6.5	16
COMMISSIONING	7.0	17
INSTALL FUEL EFFECT COMPONENTS including		
FIT TRIM AND FENDER	7.1	17
CHECK GAS PRESSURE	7.2	19
TEST FOR SPILLAGE	7.3	20
CHECK IGNITION	7.4	20
CHECK OPERATION OF FSD	7.5	20
INSTRUCT USER	8.0	21
SERVICING INSTRUCTIONS	9.0	21
REMOVE BURNER TRAY	9.1	21
MAIN BURNER INJECTOR	9.2	21
GAS TAP ASSEMBLY	9.3	21
PILOT ASSEMBLY	9.4	22
FUEL EFFECT COMPONENTS	9.5	22
MAIN BURNER	9.6	22
CONTROL KNOB	9.7	22
HINTS ON FAULT FINDING	10.0	23
NOTEPAD	11.0	24
SHORT LIST OF PARTS	12.0	26

INTRODUCTION

NO COMPONENT OF THIS FIRE IS MANUFACTURED FROM ASBESTOS OR ASBESTOS RELATED PRODUCTS.

THE BELVEDERE AND RIVIERA are a range of open fronted inset live coal effect gas fires specially designed for Pre-Cast Flue application and are also suitable for use with Brick Chimneys, twin walled or insulated Metal/Pre-fabricated Flues of 125mm minimum diameter and Flueboxes conforming to the constructional requirements of BS 715. They are fitted with a combined flame supervision and oxygen depletion monitoring device. The fire is for hearth mounting only on a non-combustible hearth. If required the fire can be fitted using a rebated surround if it is to be installed in a pre-cast flue (optional extras are required). The fire is ready for use on Natural Gas and is convertible for use on Propane Gas (LPG) using kit part number 989551.

GENERAL INSTALLATION REQUIREMENTS

In your own interest and that of safety, it is the law that all gas appliances are installed by competent persons in accordance with the current Gas Safety (Installation and Use) Regulations. **Failure to install appliances correctly could lead to prosecution.**

The installation MUST be in accordance with these installation instructions, all the relevant parts of the Local and National Building Regulations or Building Standards (Scotland) (Consolidation) Regulations and the relevant recommendations of the current editions of the following British Standards:

B.S. 5871 : Part 2
B.S. 5440 : Parts 1 and 2
B.S. 6891
B.S. 6461 : Parts 1 and 2
B.S. 715
B.S. 1251
B.S. 1289
B.S. 1289 : Part 1
B.S. 1289 : Part 2

Any other relevant British Standard Code of Practice and/or Local Building Regulations and in accordance with the rules in force.

1.0 TECHNICAL DATA

1.1 DIMENSIONS

(Overall)	mm
Height	595
Width	500
Depth	105
Forward Projection	90
Height to top of flue aperture	510
Weight	16 Kg

1.2 INPUTS AND PRESSURES

	Natural Gas		Propane Gas	
Maximum Heat Input	6.2 kW	21,154 Btu/h	5.8 kW	19,789 Btu/h
Maximum Heat Output	3.8 kW	12,956 Btu/h	3.6 kW	12,283 Btu/h
Minimum Heat Input	2.0 kW	6,824 Btu/h	3.5 kW	11,942 Btu/h
Efficiency Class	II		II	
Supply Pressure	20.0 mbar	8.0 in wg	37.0 mbar	14.8 in wg
Setting Pressure	12.2 mbar ± 1 mbar	4.9 ± 0.4 in wg	34.0 mbar ± 1 mbar	13.6 ± 0.4 in wg
Gas Rate Adjustment	NONE		NONE	

1.3 BURNER AND CONTROL DETAILS

Main Burner	989559	989559
Pilot Burner	SIT OP NG9077	SIT OP LPG9255
Injector (Main Burner)	Bray Cat 16/460	Bray Cat 10/180

Ignition	Control Integrated Piezo Spark Ignition
Control Tap	Concentric (with FSD) Model Number TESA 2377
Spark Gap	3.0mm to 5.0mm
Control Knob Settings	OFF, PILOT/IGNITION, HIGH, MED, LOW, ECON

2.0 AVAILABLE FENDERS



BELVEDERE FENDER AND ASHPAN



RIVIERA FENDER AND ASHPAN

Both the above are available in black/brass or black/chrome effect

2.1 AVAILABLE TRIMS

BELVEDERE TRIM

Available in Black with
Brass or Chrome effect insert



RIVIERA TRIM

Available in
Brass or Chrome effect



3.0 CONTENTS OF SCREW PACK

The contents of the screw pack are as follows (refer to Fig 1.): -

Key	Qty	Description
A	2	Fixing Cables
B	2	Cable Adaptors
C	2	Grub Screws
D	4	Cable Eyelets
E	4	Wall Plugs
F	4	Fire Fixing Screws
G	4	No 6 Self Tapping Screws
H	1	Restrictor
I	1	Gas Inlet Grommet
J	2	Cable Tensioning Bolts

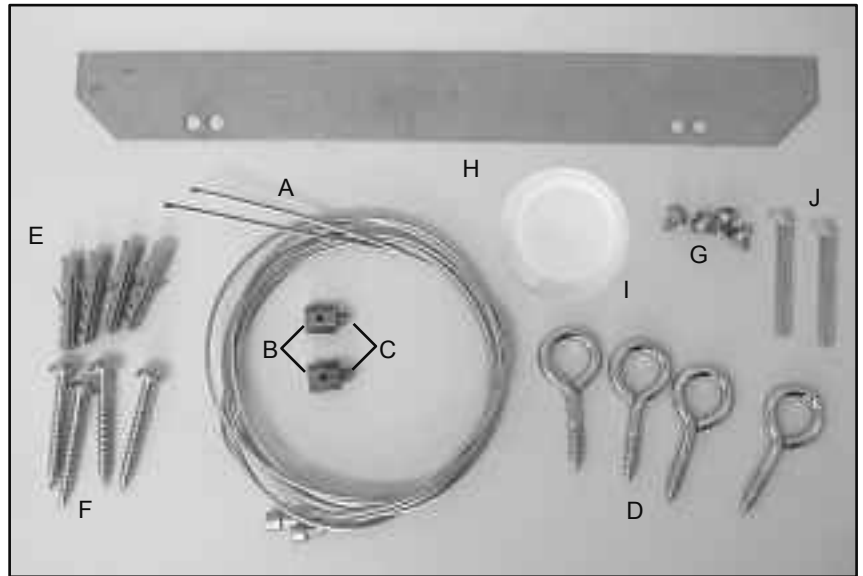

Fig 1.

4.0 CONTENTS OF COAL PACK

The contents of the coal pack are as follows (refer to Fig 2.): -

Key	Qty	Description
A	1	Base Coal Matrix
B	1	Rear Coal
C	1	Left Hand Side Cheek
D	1	Right Hand Side Cheek
E	7	Rectangular Coals

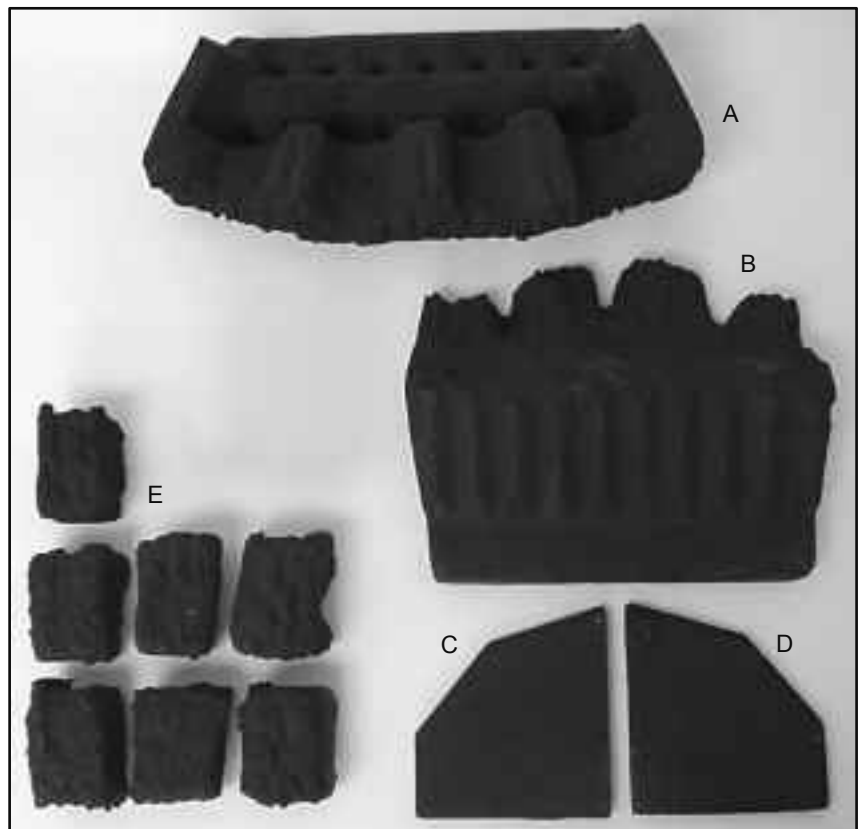

Fig 2.

5.0 CONDITIONS OF INSTALLATION

5.1 SITING GENERAL

This fire is suitable for hearth mounting only on a non-combustible hearth at least 13mm thick and measuring at least 630mm wide by 330mm deep, the periphery of which should preferably be 50mm above the floor level in order to discourage the placing of carpets or rugs over it. It **MUST NOT** be fitted directly on a combustible wall. The fire should be installed so that no part of a combustible wall i.e. not part of the fire surround but a full wall at 90° to the fire is less than 500mm from the radiant source. If this is not possible the combustible side wall must be suitably protected.

FIREPLACE OPENING

The front opening of the fireplace must be between 406mm and 457mm wide and between 550mm and 572mm high (see Section 5.2). If the opening is greater it must be bricked up until the opening is a maximum of 572mm high and 457mm wide, alternatively a non-combustible infill panel may be used to achieve the required dimensions.

DO NOT USE THE BACK OF A FIRE SURROUND OR MARBLE TO ACHIEVE THE ABOVE DIMENSIONS.

There must be a minimum flat surface area around the fireplace opening shown by the dotted lines in Fig. 4 to ensure a good seal between the fireplace and the fire. This area should be sound enough to take the wall plugs and screws supplied for front fixing. Ensure that the base of the fireplace is level with the hearth and reasonably flat to prevent the fire rocking.

Purpose built ventilation bricks or additional air vents are not normally required in the room in which the fire is fitted unless specified by the rules in force.

IMPORTANT: When fitting any heating appliance or wallpapering a room in which one is fitted, soft wall coverings such as heat sensitive wallpapers may become heat damaged or discoloured especially in the area above the fire. Please bear this in mind when installing or decorating.

5.2 FLUES AND CHIMNEYS

5.2.1 SITE REQUIREMENTS FOR 228mm BY 228mm (9in BY 9in) BRICK CHIMNEY/178mm (7in) STONE OR LINED CHIMNEY AND 125MM (5in) DIAMETER FLUE

The minimum dimensions for the fireplace opening for a brick chimney are as shown in Fig. 3. It will not normally be necessary to remove any chair brick provided the minimum depth is obtained. A chimney previously used to burn solid fuel must be swept prior to installation.

The chimney must be inspected to ensure that:

- (a) It serves only one fireplace.
- (b) It is properly sealed so that combustion products do not escape from the flue into the room.
- (c) It is not blocked by paper, rubble etc.
- (d) Any restriction such as damper, register plate, etc. must be removed or secured in the fully open position.
- (e) Any underdraught ventilation or additional air supply entering the fireplace or on the hearth must be sealed off.
- (f) It must have at least 3 metre effective flue height.
- (g) It must have a positive updraught.

CHECK THE FLUE FOR GOOD DRAUGHT

Apply a lighted paper or smoke match to the top of the opening in the fireplace. Observe if there is a definite flow into the chimney and if so proceed with fitting the fire. If no flow is indicated, warm the chimney for several minutes and then re-check. If downdraught is observed a suitable terminal must be fitted and the chimney re-checked. If persistent no-flow or downdraught condition is observed

DO NOT FIT THE FIRE, SEEK EXPERT ADVICE.

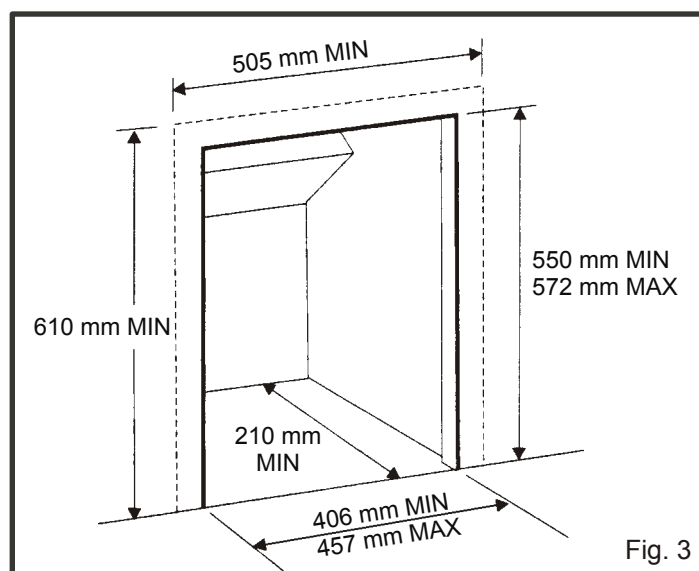

5.2.2 PRE-CAST FLUE OF MINIMUM SIZE (Fig. 4)

This fire can be installed into a properly constructed pre-cast flue conforming to B.S. 1289 : 1975 or B.S. 1289 : Part 1 : 1986 or B.S. 1289 : Part 2 : 1989 of at least 3 metres effective height and having flueways of at least 198mm by 67mm or equivalent cross-sectional area with no dimension less than 63mm. The fireplace opening width must be between a maximum 457mm and a minimum 406mm. The fireplace opening height must be between a maximum of 572mm and a minimum 550mm and a depth of at least 120mm above the hearth level.

NOTES:

1. The minimum dimensions for the flat area around the opening are 610 mm high x 505mm wide.
2. The flue spigot restrictor **MUST NOT** be fitted.

Ensure that any mortar fangs between the blocks do not protrude into the flueways and if raking blocks are used they are fitted according to the manufacturers instructions and mortar is not allowed to drop down and accumulate in the raked portions.

CHECK THE FLUE FOR GOOD DRAUGHT AS DETAILED IN SECTION 5.2.1.

NOTE: ONLY SUITABLE FOR DRY LINED WALLS

On pre-cast flue installations the walls must be dry lined over the route of the flue. Dry lining is the use of plasterboard with an air space between the wall and the plaster board. Installation must not be made into pre-cast flues that have plaster applied directly to the surface of the wall i.e. wet lined, because experience has shown that in some wet lined installations the lack of heat insulation provided by plaster can cause the plaster to shrink or crack and other decoration such as wallpaper to discolour or detach from the wall.

5.2.3 REBATED SURROUND INSTALLATION

When fitting the fire to a pre-cast flue it is possible to use a 152mm deep rebated surround. Two optional extras are required as follows: -

	Part Number
Closure Plate	989571
Spigot	989568

Fit the closure plate to the wall ensuring that a good seal is made between the plate and the wall. The plate has been designed to sit on the floor behind the rebated surround or hearth. This will position the spigot opening at the correct height for the spigot when using a 50mm high hearth. If your hearth is of a different height reposition accordingly.

If using a concealed gas connection ensure it is installed before fitting the closure plate. Knock-outs are provided for gas piping.

Fit the spigot to the rear of the fire using the four screws provided in the screw pack. Refer to Figures 5 and 6. Proceed as follows: -

Position the spigot on the rear of the fire.

Screw from inside the canopy into the spigot. It is easiest to start each screw before tightening fully.

DO NOT FIT THE RESTRICTOR

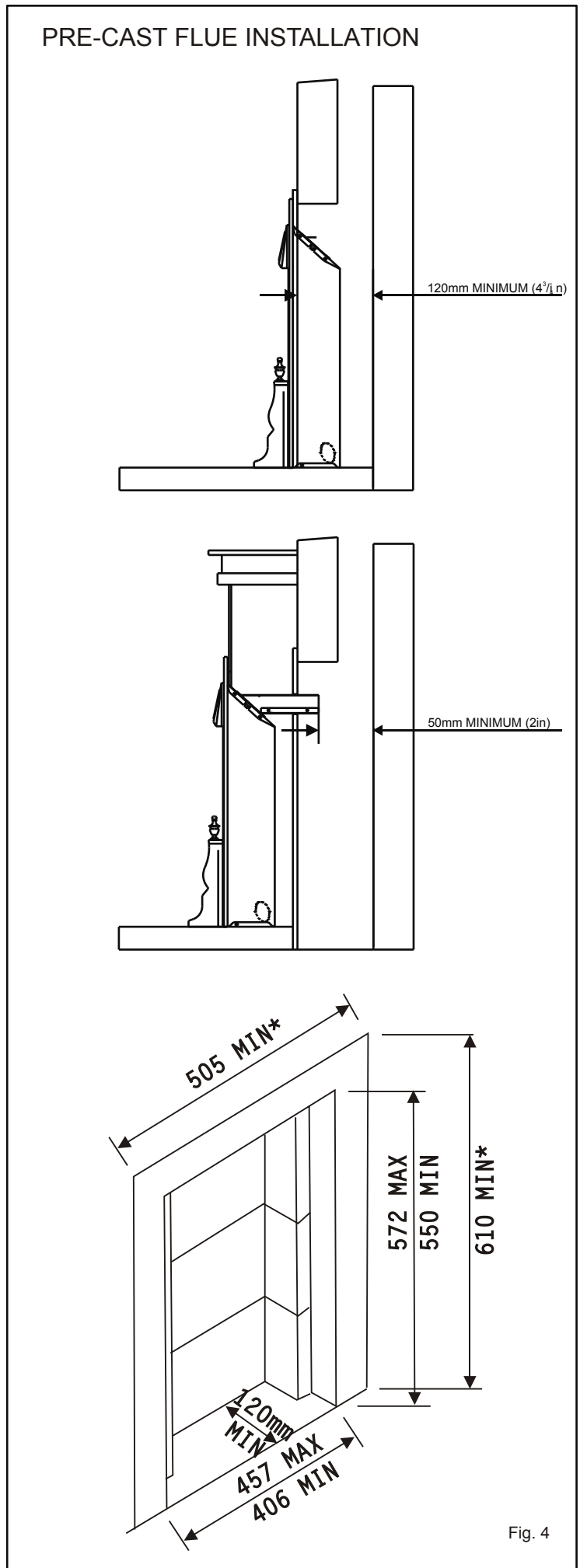

Fig. 4

Fig 5.



Fig 6.

4 SPIGOT SCREWS

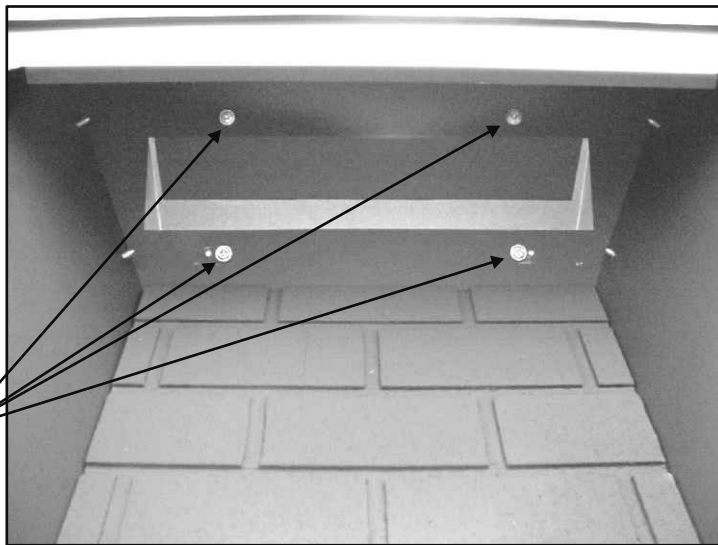
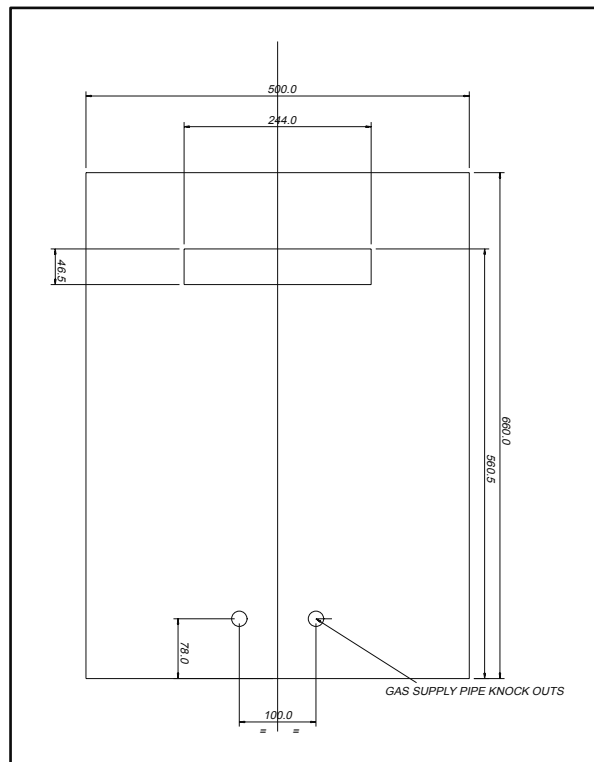

Fig 7.



5.2.4 METAL FLUE BOX/125mm DIAMETER FLUES
(Figs. 8 and 9)

This fire may be installed in a double walled or insulated metal box built to the requirements of B.S. 715 e.g. Selkirk, Product Code Number 0404805, using our fixing kit G.C. Number 159 634 Part Number 992137. The box must be lagged as detailed in Fig. 9 and mounted on a non-combustible plinth at least 25mm thick. Ensure that the base of the opening is level with the hearth. A larger box built to the requirements of B.S. 715 and insulated as in Fig. 9 may be used. The front opening must be as shown in Fig. 8. The flue should be twin walled e.g. Selkirk IL flues, or insulated type of at least 125mm internal diameter and with a minimum effective height of 3 metres. The depth of the opening must be at least 200mm.

NOTES:

1. If the flat area around the front opening of the box is less than as specified in Fig. 3, it may be necessary to use additional sealing material to achieve a good seal.
2. The flue spigot restrictor **MUST NOT** be fitted.

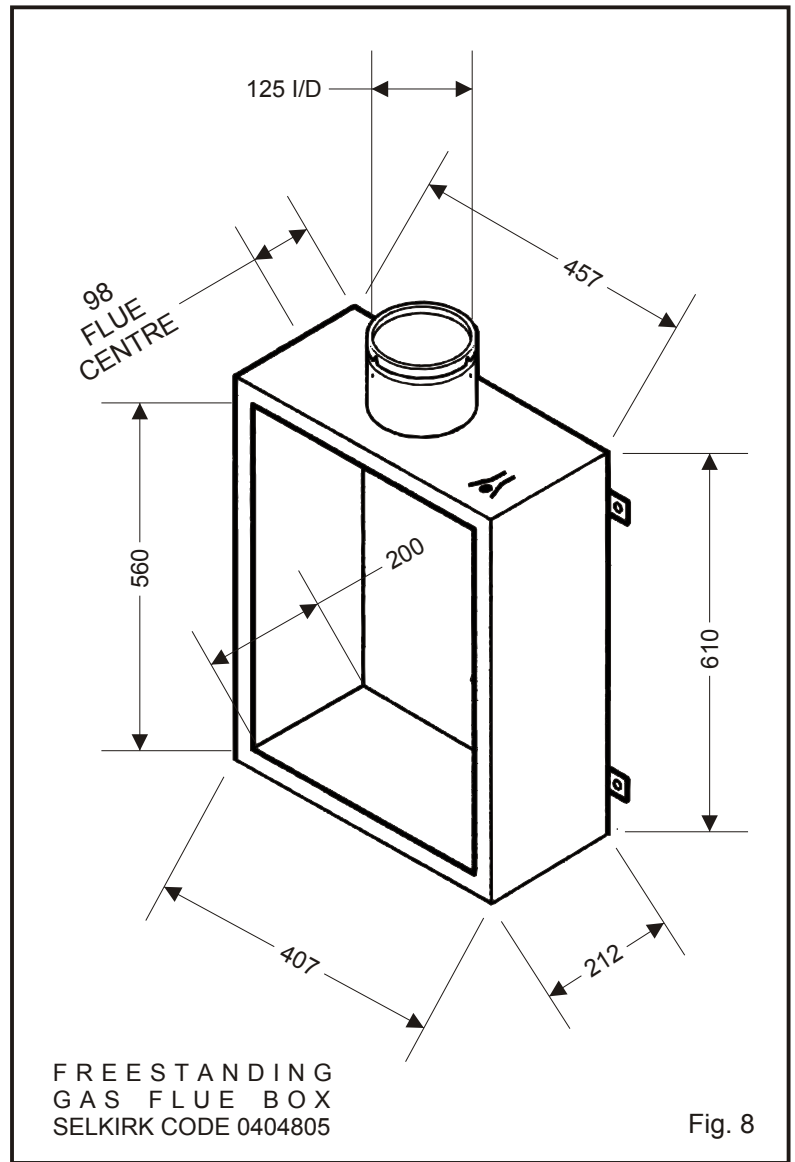

Refer to the following illustrations for configuration.

Cover the top, rear and sides of the fire housing as shown with 100mm (4in) loft insulation material as shown. If the gap between the fire housing and any combustible material is less than 100mm, squeeze the insulation material between the two surfaces.

The minimum distance from any studding or other combustible material and the flue pipe or any part of the fire housing must be 25mm (1in).

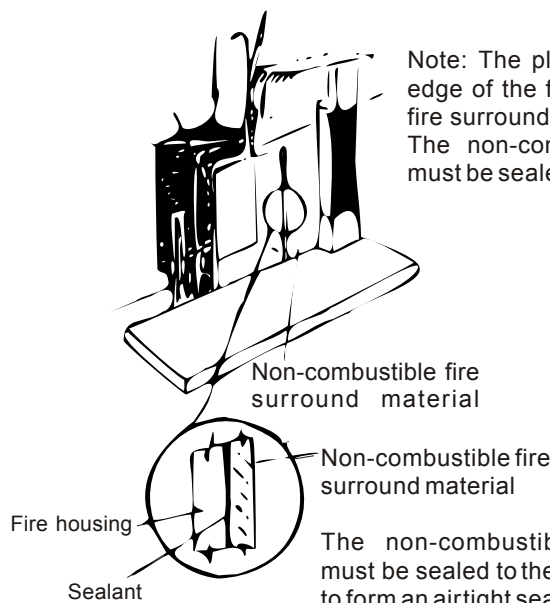

Note: The plaster board does not overlap the edge of the fire housing. Any non-combustible fire surround material used overlaps as shown. The non-combustible fire surround material must be sealed to the fire housing.

The non-combustible material must be sealed to the fire housing to form an airtight seal all around.

Fig. 9

5.3 SHELF HEIGHT AND SIDE CLEARANCES

The fire may be fitted beneath a shelf.

5.3.1 COMBUSTIBLE SHELF

A shelf may be fitted above the heater provided that it complies with the dimensions shown in the diagram.

No combustible shelf may be fitted below the minimum of 150mm.

The minimum clearance to combustible sides must comply with the dimensions in the diagram.

A minimum clearance to adjacent combustible walls, of 500mm, is required from the side of the fire.

5.3.2 NON-COMBUSTIBLE SHELF

The underside of a non-combustible shelf not more than 75mm deep must be at least 25mm above the top of the fire. This clearance is necessary for outer case removal. For deeper shelves, allow 13mm in shelf height for every 25mm increase in depth.

SIDE CLEARANCES:

A clearance of at least 25mm must be left on either side of the fire to facilitate removal of the outer case during servicing.

FIRE SURROUND:

The fire is suitable for purpose-made proprietary hearths/surrounds with temperature rating of 150°C.

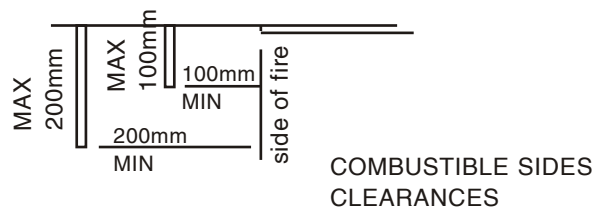
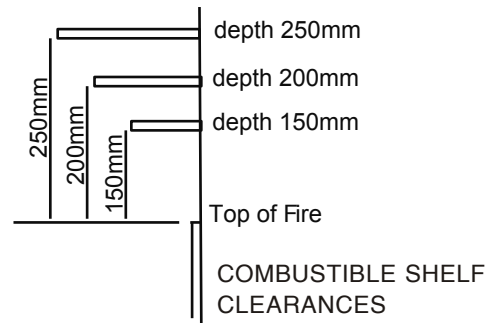

6.0 INSTALLATION OF FIRE

6.1 UNPACKING

The fire is packed with the rear brick board already fitted in position. When unpacking refer to the check list to ensure that all of the components are present and undamaged. Remove the top fitment from the carton. Remove the screw pack and spigot[†]. Lift the carton surround clear of the fire. The closure plate[†] is packed inside the inner sleeve. Remove the coal pack. Remove the trim from the fire, by lifting it upwards. The top of the trim is hooked over the top of the firebox and is held in place at the bottom by magnets. Lift the fire clear of the bottom fitment of the carton.

Pack Contents: -

- (i) 1 Fire Assembly
- (ii) 1 Coal Pack
- (iii) 1 Screw Pack
- (iv) 1 Spigot[†]
- (v) 1 Closure Plate[†]
- (vi) 1 Installation Instruction Booklet
- (vii) 1 User Instruction Booklet

[†] = where supplied

6.2 PREPARATION OF FIRE

6.2.1 SPIGOT RESTRICTOR

The spigot restrictor is supplied in the screw pack and should be fitted only in the case of installation to a brick chimney, 178mm diameter stone/lined flue of at least 3 metres effective height, with good draught. **DO NOT** fit the spigot restrictor if installation is to a **PRE-CAST FLUE** or a **METAL FLUE BOX / 5 INCH FLUE**.

Fit the restrictor with two of the self tapping screws supplied in the screw pack as shown in Fig 10.

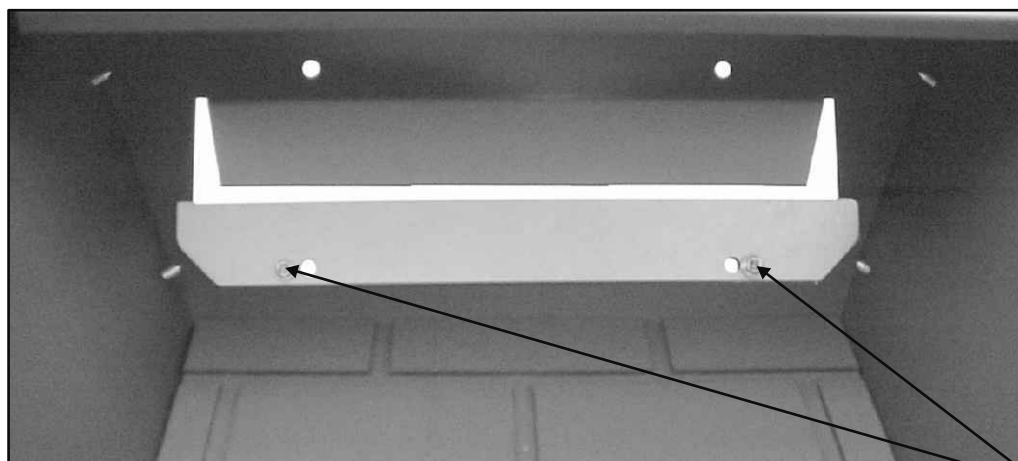

Fig 10.

2 SPIGOT
RESTRICTOR
FIXING SCREWS

6.2.2 Remove the fender mask by removing the two screws. Refer to Fig 11.

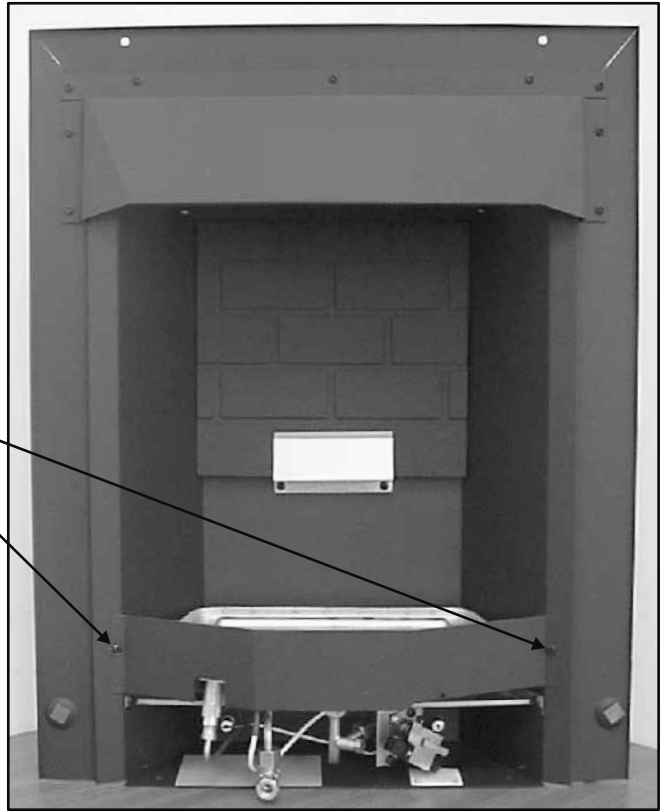

Fig 11.

6.2.3 Remove the burner tray by removing the two screws. Refer to Fig 12.

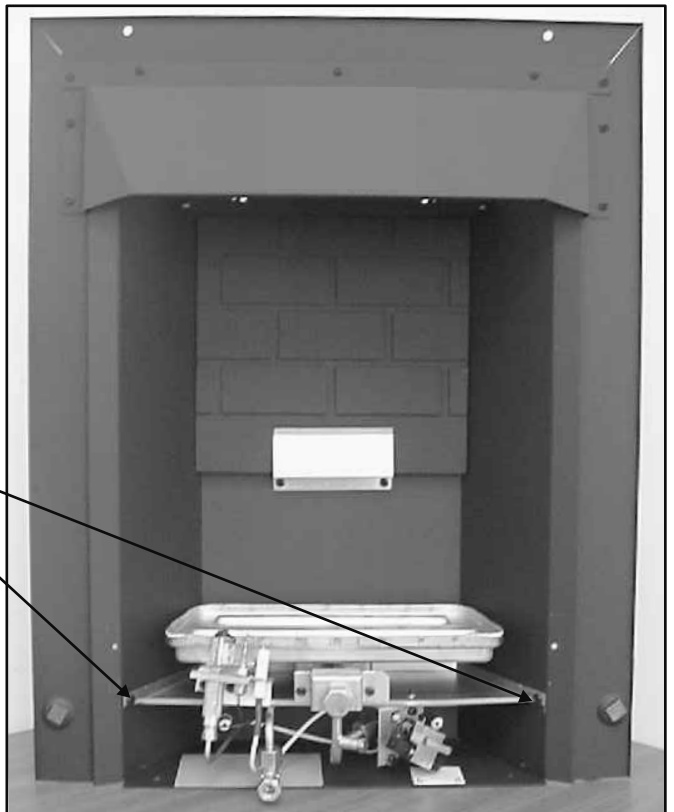

Fig 12.

6.3 METHOD OF INSTALLATION

There are two methods for securing the fire to the wall which are:

- (a) Fixing by tension cable.
- (b) Screwing the fire directly to the wall.

It is recommended, where drilling holes in the front face of the fireplace surround is unacceptable or otherwise risky e.g. a marble surround, that fixing by tension cable is employed.

IMPORTANT NOTES

- (a) If the surface of the fireplace is uneven it is necessary to prepare the surface so that a positive seal can be achieved between the fire and the wall.
- (b) If the fire is to be connected using a concealed gas connection then it is necessary to prepare the pipework prior to fitting the fire to the wall. Refer to Section 6.4.1. (Concealed Connection).

6.3.1 FIXING BY TENSION CABLE

FIT MOUNTING EYE SCREWS

Mark the position for eye screws in the back of the opening according to the dimensions in Fig. 13. Drill the four 6mm holes and plug the holes with the wall plugs. Fix the eye screws to the holes.

FIXING THE CABLE

First remove the burner tray (see Section 6.2). Prise the tabs up on each side of the firebox using a screw driver (refer to Fig 14.). Fit the cable tensioning bolts into the fire from the front, i.e. Hexagon head inside the fire. Insert the free end of each cable through the respective hole in the firebox and then through the eye screws (refer to Fig. 13). Thread the free ends of the cable through the holes in the tensioning bolts from the rear. Insert the fire into the opening so that the seal on the back of the fire is compressed against the face of the fireplace/surround. Any visible gaps indicate a deviation from flatness of the surround face which **MUST** be corrected. Pull the cable taut each side of the fire and insert the cable adaptors over the ends of the cable (Fig. 13). While keeping the cable taut slide the adaptor against the tensioning bolt and tighten the grub screw to lock the cable. Using a spanner unscrew each tensioning bolt by about 20mm to tension the cable. Prevent the cable adaptors from rotating while unscrewing the tensioning bolts. **DO NOT** cut the ends of the cables, but coil them up instead as shown in Fig 15 to facilitate refitting of the fire after servicing.

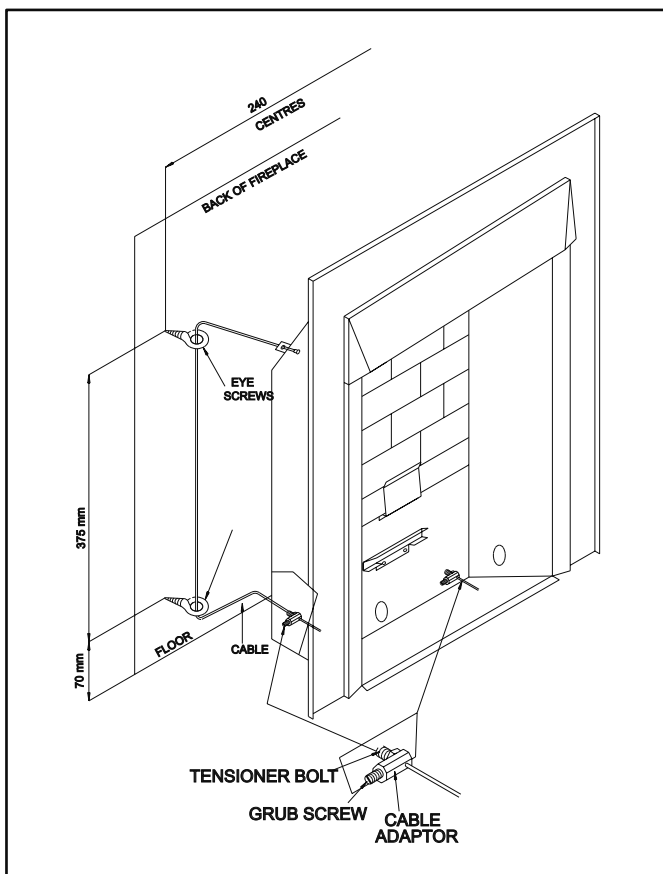

Fig 13.

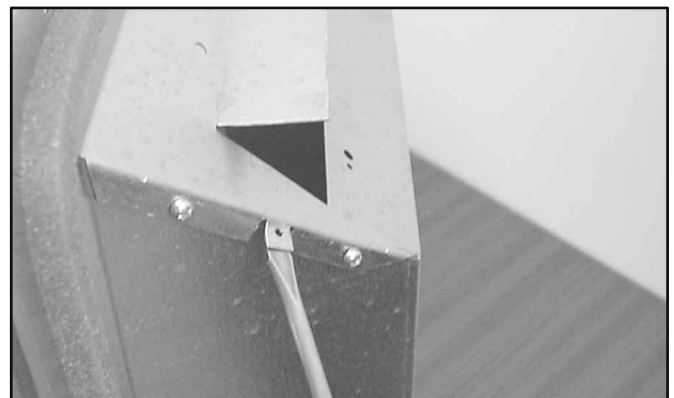

Fig 14.

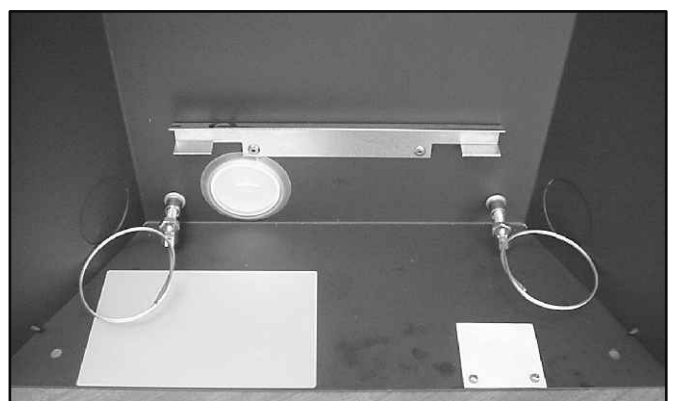

Fig 15.

6.3.2 FIXING DIRECTLY TO SURROUND FACE

Mark the four positions of the fixing holes, two on the front face of the fireplace surround and two in the floor, using the fire as a template. Drill 6mm holes and plug the holes with the wall plugs supplied. Insert the fire into the opening in the fireplace until the seal on the back of the fire is compressed against the surround face at every point. Note that any visible gaps between the surround face and the seal indicate a deviation from flatness on the surround face and **MUST** be rectified. Screw the fire to the wall.

6.4 GAS CONNECTION

NOTE: The appliance must be connected to gas with rigid or semi-rigid tubing, from either the right or left hand side, or by concealed connection (see below). The supply pipe to the fire should be installed so that it is easy to remove the fire from the opening during servicing. An isolation inlet elbow is fitted to the burner assembly for isolation of the fire for servicing at a later date.

If a concealed connection from within the fireplace is required then, before the appliance is fitted into the fireplace, it will be necessary to extend the supply line so that it will project through the sealed opening situated at the back of the firebox to the appliance inlet elbow.

6.4.1. CONCEALED CONNECTION

Remove the isolation elbow from the burner assembly. Fig 16.



Fig 16.

Knock out at the required position using a hammer and screwdriver to gently but firmly knock out the hole. Refer to Fig 17. Push in the hole the large grommet provided in the screw pack. If necessary the grommet can be softened by placing it on top of a kettle whilst it is boiling until supple.



Fig 17.

Cut a cross in the centre of the grommet to suit the size of supply pipe. Fig 18.



Fig 18.

Push the supply pipe through the hole just created and connect the isolation elbow removed from the burner assembly. Refer to Fig 19. The end position is shown in Fig 20. The pipe run from the supply line up to the rear opening in the firebox must be kept clear of the area which will be taken by the box when it is installed.

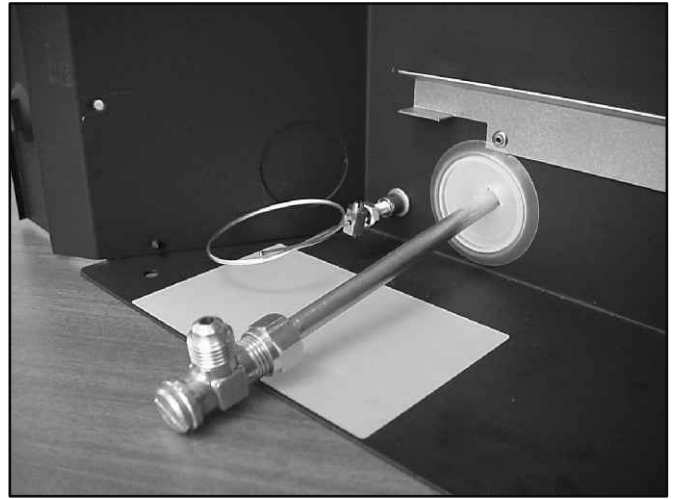

Fig 19.

6.5 TEST FOR GAS SOUNDNESS

The gas installation, including metre, should be inspected and tested for gas soundness and purged.
Refer to B.S. 6891 when performing gas soundness testing.

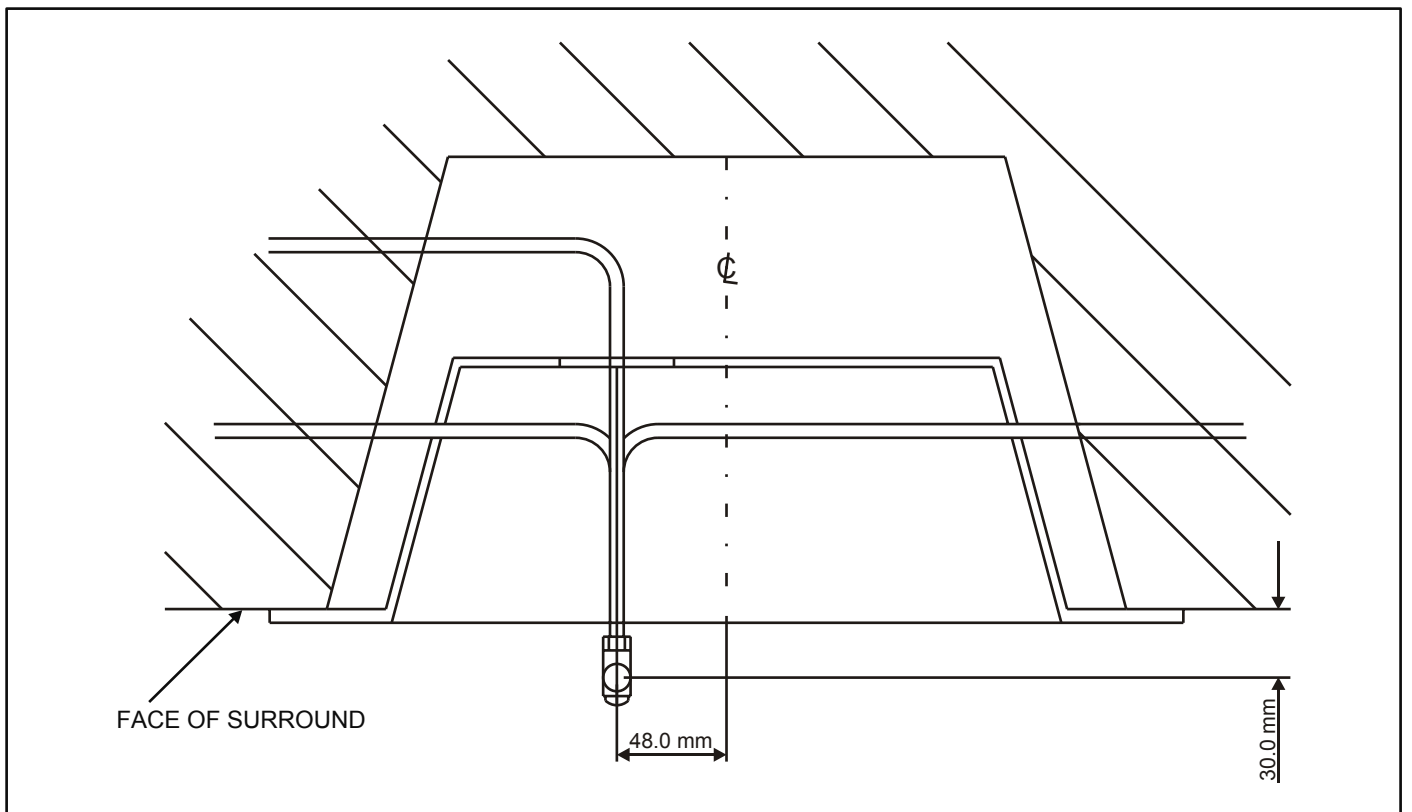

Fig 20.

7.0 COMMISSIONING

7.1 INSTALL FUEL EFFECT COMPONENTS

The fuel effect components comprise:

- (a) Rear Coal
- (b) Two Side Cheeks
- (c) Coal Bed
- (d) Seven Rectangular Coals

The Coal Bed and the loose coals are illustrated in Fig 2. The fire is supplied with the rear brick effect panel already fitted as illustrated in Fig 11.

Unpack the pack containing the coal bed and the loose coals and check that these are undamaged.

DO NOT INSTALL THE FIRE WITH BROKEN OR MISSING COALS. USE ONLY THE COALS SUPPLIED WITH THE FIRE.

1. The underside of the coal bed has grooves matching the raised ports of the burner top. Fit the coal bed by placing it onto the burner. Take care to avoid damage as you insert it past the pilot burner (Refer to Fig 21.). Ensure that it is correctly located in the burner tray by sliding it sideways and front to back.
2. Insert the side cheeks by sliding them down the side of the matrix until they touch the rear brick effect panel. (Refer to Fig 22.)

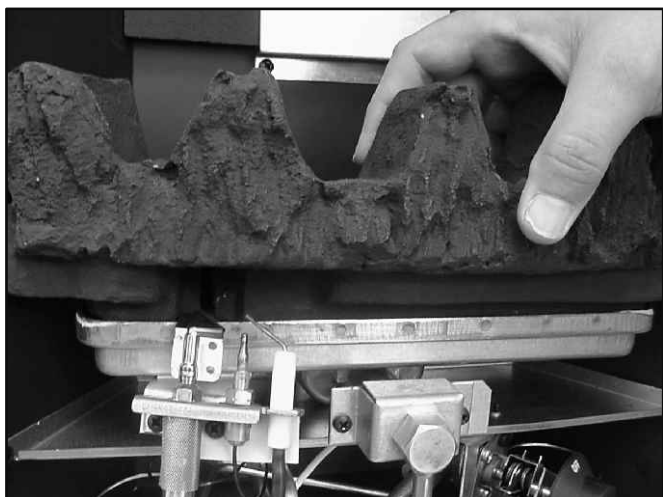

Fig 21.



Fig 22.



Fig 23.



Fig 24.

3. Lower the rear coal into position at an angle as shown in Fig 23.

4. Ensure that the rear coal drops back towards the rear brick effect panel and seats correctly into the base coal. (Refer to Fig 24.)

5. Fit the trim to the fire by hooking it over the top of the firebox top. Refer to Fig 25.



Fig 25.

6. The bottom of the trim is held in place with magnets. Push the bottom of the trim at each side onto the magnets. **NOTE:** If the magnet on either side came away with the trim on removal, transfer it back to the “bump” on the fire before re-fitting the trim. Refer to Fig 26.

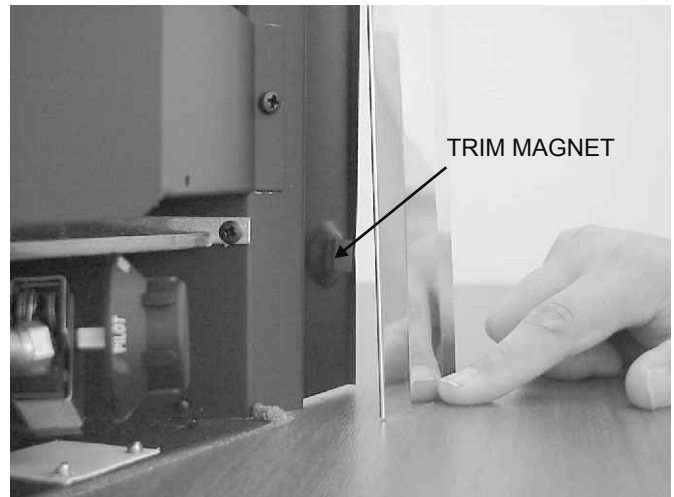

Fig 26.

7. Position the fender centrally and slide towards the fire until it touches the base coal. Refer to Fig 27.



- Place 4 rectangular coals onto the base coal with their decorative faces visible. They should have the front end touching the back of the fender or inline with it. Refer to Fig 28.



Fig 28.

- Place the 3 remaining rectangular coals resting in the 'V' s just created and leaning back to rest on the rear coal. Refer to Fig 29.



Fig 29.

7.2 CHECK GAS PRESSURE

Remove the pressure test point screw located on the injector feed pipe just left of centre on the fire. Connect a pressure gauge, depress the control knob and rotate to the PILOT/IGNITION position until the piezo sparks. Keep the knob depressed after the pilot has lit to activate the FSD and then rotate the knob to the HIGH position. Check that the gas pressure is as specified in Section 1.0 Technical Data. Turn off the fire and disconnect the pressure gauge. Replace the test point screw, relight the fire and test for gas soundness around the sealing screw using a suitable leak detection fluid.

7.3 TEST FOR SPILLAGE

A test for spillage must be made before the installed fire is left with the user. This is carried out in the following manner. Light the fire and leave at HIGH rate. Close all the doors and windows in the room and after the fire has been alight for five minutes insert a lighted smoke match into the notch in the canopy in a horizontal direction with the tip 50 mm inside the canopy (See Fig. 30). Hold the match in a metal tube. If all of the smoke is drawn into the fire the installation is satisfactory. If in doubt, repeat the test after a further ten minutes.

If there is a fan or a fan operated appliance in a connecting room then the spillage test must be repeated with the fan running and all inter-connecting doors between the fan and the fire left open. If the fan and the fire are in the same room, close all windows and doors connected to the room. Switch on the fan and repeat the spillage test.

If spillage is detected, inspect the sealing of the fire to the surround / hearth. If this is satisfactory proceed as follows:

If a spigot restrictor was fitted, turn the fire off and remove the spigot restrictor. Re-light the fire and repeat the above spillage test. If there is still evidence of spillage then there may be a fault with the chimney or insufficient air in the room. If the cause of the spillage cannot be corrected **DISCONNECT THE FIRE AND SEEK EXPERT ADVICE.**

Fig 30.

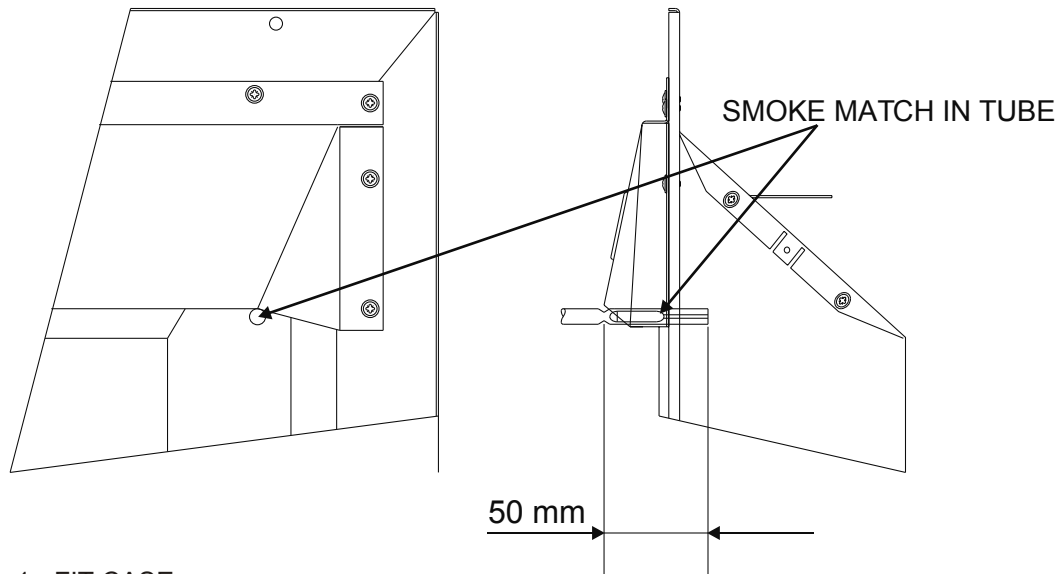

1. FIT CASE.
2. LIGHT FIRE AND LEAVE AT FULL RATE
3. CLOSE ALL DOORS AND WINDOWS
4. AFTER 5 MINUTES INSERT SMOKE MATCH AS SHOWN IN THE DIAGRAM.
5. SMOKE WILL BE DRAWN INTO THE FIRE IF INSTALLATION IS SATISFACTORY.
6. IF SPILLAGE OCCURS, WAIT FOR 10 MINUTES AND REPEAT THE TEST.
7. IF SPILLAGE IS STILL EVIDENT PROCEED AS IN SECTION 7.3.

7.4 CHECK IGNITION

Check that ignition of the pilot and the cross lighting to the main burner is satisfactory.

NB. The spark gap between the electrode and thermocouple tip should be between 3.0 and 5.0mm (See Fig 31.).

7.5 CHECK OPERATION OF FSD

Leave the fire running on HIGH rate for 5 minutes and then turn off the gas at the service cock. After 3 minutes turn the service cock on again. If the gas has stopped flowing the FSD has operated satisfactorily.

NOTE: You may hear the FSD valve close within the 3 minute period but always check that the gas has stopped flowing.

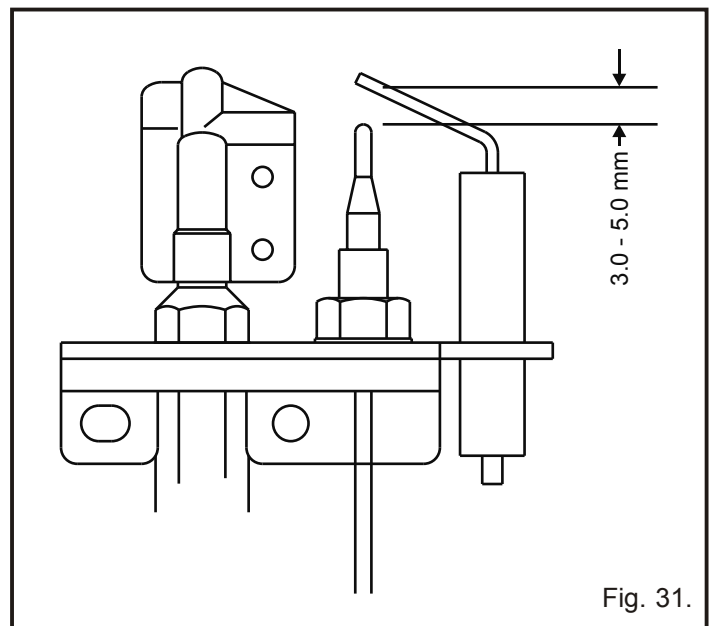

Fig. 31.

8.0 INSTRUCT USER

Refer to Users Instructions

Make sure the user understands the following:

- (a) How to light and operate the fire.
- (b) The fire can be lit with a match or taper in the event of failure of the spark ignition.
- (c) Demonstrate the removal and replacement of the coals. Advise on the need to clean these regularly.
- (d) Advise that for safe and efficient operation, the fire should be serviced annually by British Gas or a CORGI registered service agent.
- (e) Explain to the user the functioning of the combined flame supervision and atmosphere monitoring device as detailed in Section 9.4. Stress that if this device repeatedly shuts off the fire, the fault must be rectified immediately by a competent person.
- (f) When the fire is first lit a slight smell and light smoke may be noticed but this will clear away with a few hours of use on HIGH.
- (g) Advise the user to carefully clean the base of the fire with a vacuum cleaner regularly.

Hand over the Users Instructions

9.0 SERVICING INSTRUCTIONS

IMPORTANT NOTES

1. Turn off the gas supply to the fire before starting any servicing.
2. Always test for gas soundness after servicing or exchanging any component.
3. Remove the fire from the surround and inspect the catchment space for build up of debris on every service visit.
4. Check the fire for clearance of products on every service visit.
5. Remove any lint from the top of the main burner and from around the aeration hole of the pilot and main burner.

9.1 REMOVE BURNER TRAY

1. Remove the fender and ash-pan cover.
2. Remove the loose coals and coal bed.
3. Isolate and disconnect the gas supply at the inlet to the fire.
4. Remove the two screws securing the fender mask to the firebox and remove the fender mask.
5. Remove the two screws securing the burner tray to the firebox and slide out the burner tray.

9.2 BURNER INJECTOR

1. Remove the burner tray (Section 9.1 above).
2. Undo the union nut at the gas valve end.
3. Undo the two screws securing the injector bracket to the burner manifold and remove the pipe assembly..
4. Unscrew the injector from its holder its holder, and remove the injector.
5. Replace with the new injector.
6. Re-assemble in the reverse manner.

9.3 GAS VALVE / FSD ASSEMBLY

1. Remove burner tray (Section 9.1 above).
2. Turn the tray upside down, taking care not to damage the pilot burner head.
3. Undo the gas connections to the gas valve.
4. Release the thermocouple nut and ease out the probe.
5. Disconnect the ignition lead from the spark generator.
6. Remove the two screws securing the gas valve to its bracket and remove the gas valve.
7. Replace with the new gas valve/fsd assembly.
8. Re-assemble in the reverse manner.

9.4 PILOT ASSEMBLY

The pilot is an atmosphere sensing device and must be replaced as a complete unit. Repair must not be undertaken.

NOTE: If the fire keeps going out or exhibits signs of nuisance shut off, check the operation of the pilot as follows:-

- (a) Check the pilot lint trap for blockage. Remove any lint present.
 - (b) Inspect the pilot flame, if suspect check the gas supply. Clear blockage if necessary. If flame is still suspect replace pilot assembly.
 - (c) Check the thermocouple. If faulty replace the pilot assembly.
 - (d) Check the magnet unit in the gas valve. If faulty replace the valve.
 - (e) Check the thermocouple break micro switch and connections.
 - (f) Check the ventilation in the room. Vitiation may be due to lack of sufficient air supply.
 - (g) Check for satisfactory clearance of combustion products. Vitiation may be due to spillage of combustion products into the room.
1. Remove burner tray (Section 9.1 above).
 2. Release the pilot supply pipe at the pilot end and ease out the pipe.
 3. Undo the thermocouple nut at the gas valve end and ease out the thermocouple.
 4. Pull off the spark lead at the pilot end.
 5. Remove the two screws securing the pilot assembly (and insulation pad) to its bracket.
 6. Fit the new pilot assembly.
 7. Re-assemble in the reverse manner.

9.5 FUEL EFFECT COMPONENTS

The loose coals, coal bed, rear coal and the side cheeks simply lift out. To replace the rear brick panel proceed as follows:

1. Remove burner tray (Section 9.1)
2. Remove the screws securing the lower support and slide out the brick effect panel.
3. Replace with a new one, and re-assemble in reverse order.

9.6 MAIN BURNER

1. Remove burner tray (Section 9.1)
2. Undo the two screws securing the pilot assembly to the burner.
3. Undo the two screws securing the injector to the burner manifold.
4. Turn the tray upside down.
5. Remove the screws from the pilot.
6. Undo the two screws securing the burner to the tray and remove the burner.
7. Fit the new burner and re-assemble in the reverse manner remembering to refit the pilot (including insulation pad)..

9.7 CONTROL KNOB

1. Remove the ash-pan cover.
2. Pull the control knob from the spindle.
3. Replace with a new knob ensuring that the 'D' shape in the hole lines up with the flat on the spindle.

10.0 HINTS ON FAULT FINDING

The following are possible fault conditions. Check the items mentioned and repair or replace parts as necessary. The list is not exhaustive but a fair outline of possible faults.

1. **No Spark**

- Check spark by manually operating the spark generator.
- Check the spark gap and electrode alignment (see Fig 31). The electrode, thermocouple probe and horizontal arm of the pilot burner should be in a straight line.
- Inspect the spark lead, ensure firm contact at the ends and that there is no shorting out of spark at either end.

2. **Spark but the pilot does not light.**

- Verify availability of gas at the pilot burner, if possible, light with a match.
- If gas is available, proceed as in 1 above.
- If gas is not available, check the pilot burner and supply pipe for blockage.
- Ensure gas is available at the pilot port of gas tap, if not replace the tap.

3. **Pilot lights but goes out on heat setting.**

- Check for linting of the pilot lint trap filter (refer to Fig 32.) and the aeration hole under the filter.
- Pilot starvation due to partial blockage. Clean the pilot gas supply line. See also 2(c) and 2(d) above.

4. **Nuisance shut off.**

- Inspect the pilot flame.
- Check the thermocouple. If faulty replace the pilot assembly.
- Check the magnet unit in the gas tap. If faulty replace the tap.
- Check the ventilation into the room. Vitiation may be due to the lack of sufficient air supply.
- Check for satisfactory clearance of combustion products. Vitiation may be due to spillage of combustion products into the room.
- Remove spigot restrictor if fitted.

5. **Main burner popping.**

Remove the loose coals and coalbed. Light the fire and inspect the burner for cracks and leakage. Replace the burner if necessary.

6. **Poor flame picture.**

- Remove the burner assembly. Check the alignment of the burner ports with the holes in the coalbed. Ensure the ports are clear.
- Re-assemble correctly and check the flame picture.
- Check the gas rate.

7. **Sooting.**

Proceed as in 6 above.

8. **Spillage.**

- Check the seal of the fire to the wall/surround.
- Inspect the chimney.
- Remove the spigot restrictor if fitted.
- Check the coal arrangement.

Fig 32.

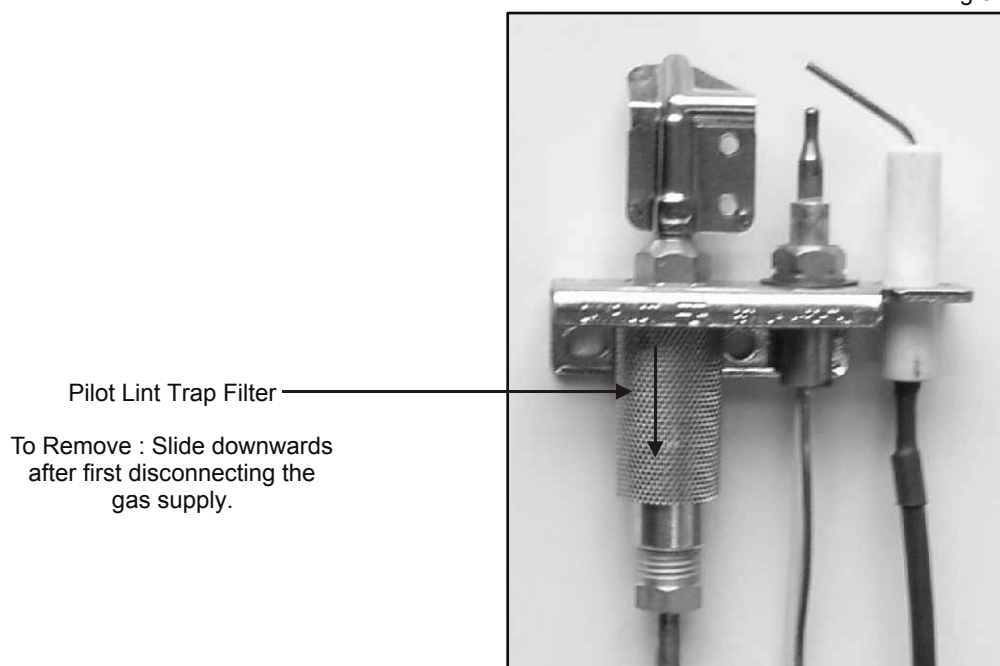

11.0 NOTEPAD

A series of horizontal dotted lines for writing.

11.0 NOTEPAD

A series of horizontal dotted lines for writing.

12.0 SHORT PARTS LIST

PART NUMBER	DESCRIPTION
822189	Gas Tap / FSD Assembly
992220	Control Knob
822174	Pilot Assembly (Natural Gas)
56/282	Pilot Assembly (Propane Gas)
993911	Ignition Lead
989576	Rear Brick Panel
989583	Coal Pack
822327	Main Burner Injector (Natural Gas)
822329	Main Burner Injector (Propane Gas)
990454	Aeration Plate (Propane Gas)
822328	Trim Magnet
822326	Gas Inlet Grommet

989510 Issue 3 - January 2001

ROBINSON WILLEY LIMITED
Mill Lane, Old Swan, Liverpool. L13 4AJ. England.
Telephone: 0151-228-9111 Fax: 0151-228-6661
www.robinson-willey.co.uk

AMMENDMENT HISTORY

11/01/2001 Page 8 text and Fig 3 dimensions
Page 9 text and Fig 4 dimensions
Issue upped to 3